

PART 10

General Container Operations Including Waste Shipments

Chapter 41	393
Stuffing, Stacking and Lashing Containers	
Chapter 42	425
Container Top Safety	
Chapter 43	429
Container Crime	
Chapter 44	433
Waste Shipments in Freight Containers	



Chapter 41

Stuffing, Stacking and Lashing Containers

There are three main categories of damage to cargo shipped by container:

1. The consignee receives the container with a broken seal. In such circumstances, the carrier may be held liable for damage and/or loss to the cargo.

The safety measure from the carrier's point of view, therefore, should be to ensure they reject any containers found with a damaged/broken seal at the load port.

In theory, the seal must be checked at each stage in the logistic chain where a container exchanges hands. If found and unreported, the next entity in the chain who finds the broken seal may claim for damages from the previous one. It must be borne in mind at all times that a broken seal may mean more than damage or loss of cargo; it may also mean that criminals have introduced illicit items such as drugs or even humans into the container. The carrier is advised, therefore, to report any broken seal to the shipper as well as to their P&I Club. A survey may be appropriate

to establish any pilferage, loss or damage to the cargo, after which the container may be allowed for shipment.

2. The container and the cargo is damaged. In such a case, a joint survey by the shipper or consignee and the carrier (P&I Club) will be carried out to establish the extent of damage. This survey report will define the liability for both parties.



Courtesy of New Zealand Defence Force

Figure 41.1: The grounding of MV 'Rena' off New Zealand in 2011 overstressed many container twistlocks, resulting in a partial collapse of container stacks.

3. The consignee opens the container and finds the cargo damaged. In this case, the carrier may repudiate the claim on the basis that the container was packed by the shipper, provided that the ship did not suffer extreme weather damage during the voyage.

Reference should also be made to the guidance and publications provided by the shipping lines, which contain practical advice on container securing components and securing systems. A widely used publication is the *Safe Transport of Containers by Sea: Industry Guidance for Shippers and Container Stuffers* which is published by the International Chamber of Shipping and the World Shipping Council (Reference 65).

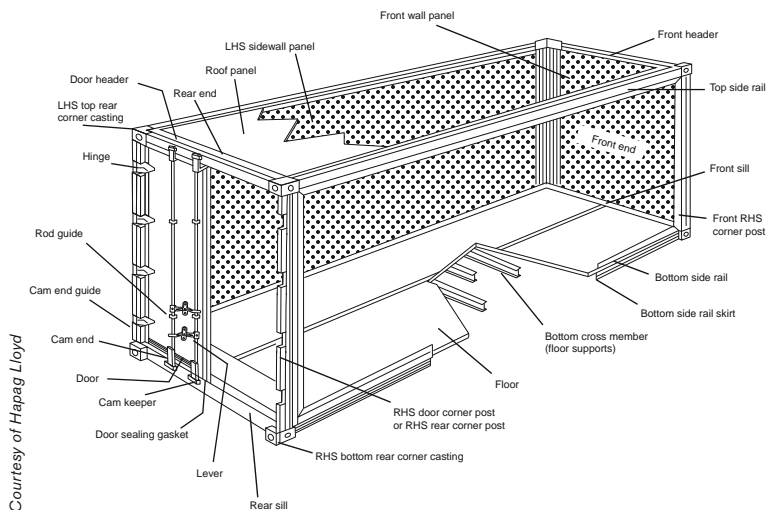

Figure 41.2: Components of a container.

41.1 Stuffing

Containers are often packed at places that are distant from the marine loading terminal, sometimes several days' journey. It is, therefore, important that everyone involved with the packing of containers, at whatever stage in transit, is fully aware of the stresses that can be generated in the structure of the container itself and in the cargo within it. It is essential that containers are in sound structural condition each time they are put into service and that they are suitable for the cargo to be carried.

It should always be borne in mind that the side panels, end panels and roof panels of an ISO container are not normally strength members.

Beneath the floor timbers, there are metal cross bearers and it is generally these bearers that provide the floor's strength. Additionally, the corner posts, front and rear headers, and front and rear sills provide the internal strength members. Whenever bracing is to be used in vertical, horizontal or diagonal form, it must act against those members and the floor bearers and no others. Bracing and/or end chocking against side, end and roof panels will result in disaster.

Unlike breakbulk cargo, the ship's Master and officers do not sight, or have any control over, the contents of containers or the methods by which the contents have been packed and secured.

If the contents of just one container are improperly packed, lack adequate securing arrangements or are inappropriate for container carriage, they may break adrift when the ship encounters heavy weather, risking the safety of the other containers, their contents and the ship itself.

In one example, round steel bars, inadequately secured, broke adrift within a container third in stack on deck, pierced and went through the container's side panels and shattered a corner post of the adjacent container, creating a domino collapse of the other units. A single block of granite, lacking securing arrangements within the lower tier of a below-deck stack, broke through the container's side panel and fell corner down, piercing the double-bottom fuel oil tank below. The consequential fuel oil flooding of the hold and lower level damage to base containers was a costly business.



Figure 41.3: Poorly stuffed container – note the damaged packages, the pallet on top of cartons and the apparent lack of securing arrangements.



Courtesy of PO2 Prentice Danner, DVIDS

Figure 41.4: Inspection of goods in a container terminal.



Figure 41.5: Damage caused to a container by poorly secured coils.

Casualty investigation often reveals that horizontal spaces, ie fore-and-aft and longitudinally, are generally adequately chocked, but the vertical component is entirely neglected. When a ship is pitching and yawing in a seaway, vertical acceleration and deceleration forces acting on cargo components can attain values of 2 g, which means that, as the vessel goes up and comes down, the load on the securing arrangements will be equal to twice the static weight of the cargo item. If there is no arrangement to secure the cargo to the floor of the container, the cargo will lift, and once it lifts it will start to shift, and once it starts to shift it will go on shifting!

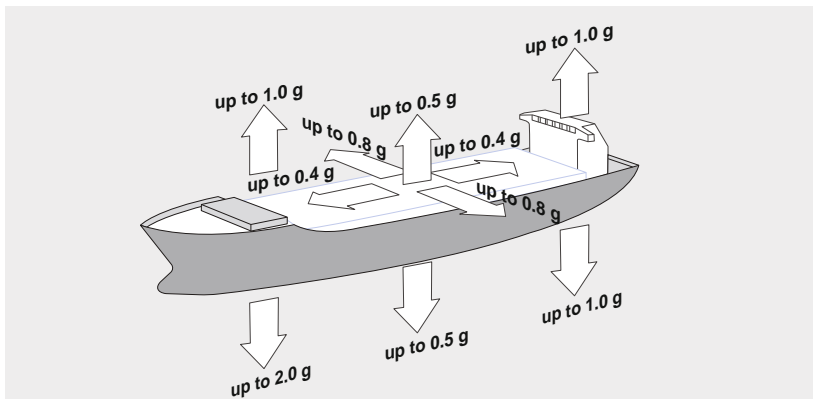

Figure 41.6: Potential accelerations at sea.

Where relatively lightweight cartons or good timber cases can be afforded tight block stowage, there will be little need for additional securing arrangements. However, where plastic jars, bottles, barrels or lightweight cartons with frail contents are to be stowed to the full internal height, it may be necessary to provide mid-height flooring so that the lowermost items do not suffer compression damage or collapse.

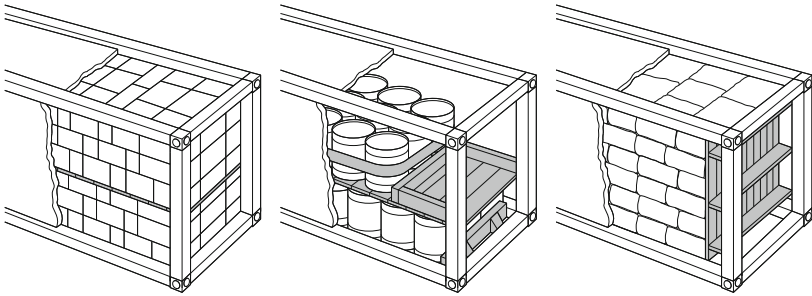

Figure 41.7: Flexible flooring arrangement.

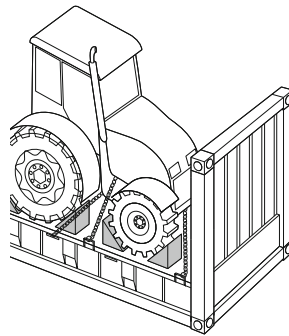
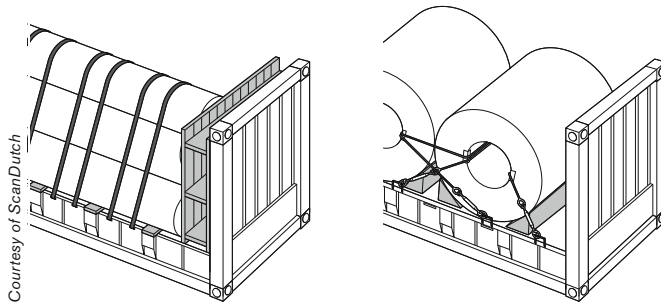

Figure 41.8: Heavy machinery on a 'flat'.



Courtesy of ScanDutch

Figure 41.9: Securing points.

Where bags, cartons or cases do not occupy the full internal space, chocking and bracing with timbers and/or air bags is necessary.

Where heavy items are involved, securing with downward leading wire lashings and/or strapping to 'D' rings attached to the upper parts of the floor bearers will be required.

It is important that the correct form of container is used, because not all have provision for mid-height flooring to be fitted, and not all are provided with 'D' rings.

Steel coils, steel pipes and bars, and heavy machinery items should be shipped on specially designed 'flat racks', 'flats' or 'sledges' (see Figure 41.7). These units are strengthened for such loads and adequate securing terminal points are provided (see Figures 41.8 and 41.9).

41.2 Container Stuffing Considerations

The packing and securing of goods inside a container plays a vital role in safe transportation of goods to their destination, but this is never in the control of the ship's officers. In some ports, some carriers require container stuffing to be sample checked to ensure that the contents, particularly if there are any dangerous goods, have been secured properly.

Further inspections of the goods may also be made by the harbour or customs authorities to establish customs duties and export taxes, etc and, where this is done, the carriers can utilise the opportunity to check the stuffing of cargoes.

The ship's officers must play their role in observing and reporting any abnormalities. Consideration should be given to the following.

1. Cargo may be containerised for a prolonged period, during which changes in temperature may lead to generation of mould, bacteria, fungus or other microorganisms, particularly where the cargoes are hygroscopic and there is a lack of proper ventilation. To avoid biological contamination, many countries require containers to be fumigated and then sealed prior to shipment.
2. When different commodities are stuffed together, the compatibility characteristics of each cargo should be noted. Some examples of non-compatible cargoes are:
 - a) cargoes that emit odours stowed with odour sensitive cargoes
 - b) hygroscopic cargoes stowed with cargoes that may absorb moisture. If unavoidable, hygroscopic cargoes should be loaded under other cargoes with a layer of dunnage and a protective cover such as a tarpaulin laid on top of the hygroscopic cargo.
3. Hygroscopic cargoes are likely to give off moisture during transportation leading to condensation, commonly referred to as 'container sweat' or 'container rain'. Condensation may damage the cargo and may lead to biological contamination. Desiccants may be provided, but these are not a failsafe means of preventing condensation.
4. Certain sensitive cargoes, such as wet hides or salted skins, require containers to be lined with plastic sheeting or packing paper.

5. Containers are fitted with lashing/securing points with the longitudinal beams on the floor or roof and also with the corner posts. Each lashing point has a predetermined SWL (safe working load), which is generally 1 t but may vary for older containers. Container walls are not designed to be load bearing, so nothing should be attached to them.
6. When palletised cargo is loaded into a container, the space utilisation will depend on the size of the pallet in relation to the size of the container. Generally, there will be some void spaces between pallets and these must be filled in with air/inflatable bags or dunnage. Where pallets are stowed more than one high, their longitudinal movement within the container must also be blocked by the use of appropriate lashing or chocking.
7. Distribution of weight within a container should avoid:
 - a) Loading heavier items at one end or side of the container
 - b) Stowing heavier items above light items. Impact on the centre of gravity of the container with respect to weight distribution should also be considered.
8. Cargo items with sharp edges, protrusions or awkward shape must not be stowed next to soft packages, to avoid damage during even the smallest movement within the cargo.
9. Any cargo that is liable to leak should not be stowed on top of other cargo.

41.3 Containers in Stack

Most ISO containers are designed to allow nine-high stacking when empty. They should be placed and must stand on the four lower and four upper corner castings alone, with the appropriate stacking/locking components between. The bottom and top side rails, the front and rear sills and headers, and the underside floor bearers should remain free of vertical stacking contact at all times if transient racking stresses are to be avoided.

There are many different securing systems and problems may arise if ships' officers/charterers' superintendents are unfamiliar with a specific system.

Container stack racking failures may occur in non-purpose-built vessels if charterers insist on stacking containers in the holds and on the weather deck in a manner that would not be approved even in a purpose-built ship. Unfortunately, stack collapses within the holds, and within weather-deck stacks, occur just as frequently in purpose-built vessels.

Container stack failures generally arise from three causes that involve unacceptable racking stresses in one form or another:

- Substandard components and seaworthiness
- weight management problems in stacks
- mixed unit sizes.

41.3.1 Substandard Components and Cargoworthiness

A vessel's container stowage and securing arrangement can easily be undermined if substandard and/or incorrect components are utilised. Maintaining securing equipment in good order, both fixed and portable, requires considerable time and effort.

Whatever regulations, standards or codes of practice are issued, the integrity of a vessel's container stowage and securing arrangement can only be ensured by regular inspection of the securing equipment. The securing arrangement can be undermined by one or more of the following:

- 'Rogue' securing equipment
- improperly maintained securing equipment
- complacency in inspection of the equipment and record keeping
- insufficient supply of correct securing equipment
- overloading of the securing equipment.

Portable securing equipment

If substandard equipment is used, it can fail at a lower load than its design rating, thereby resulting in failure of the overall securing system and possible collapse of the container stow.

The following aspects should be considered during periodic inspection of container securing equipment:

- Inspection of the twistlock complement to ensure that rogue twistlocks, ie ones with an opposite locking action to the ship's standard complement, have not made their way on board. When left-hand and right-hand locking twistlocks are fitted with similar shaped handles, which can be the case, it is not always possible to differentiate between them once used in the same stow. Even if the stevedores are aware of the difference, any subsequent checks by other people could allow disengagement if the handles are all actuated in the same direction on the premise that some twistlocks had not been properly locked in the first instance.

ISO Standard 3874, *Series 1 freight containers – handling and securing*, includes the physical and functional requirements for various items of portable securing equipment as an appendix to the standard itself

(Reference 66). ISO Standard 1161, *Series 1 freight containers – corner and intermediate fittings* establishes the basic dimensions and the functional and strength requirements of corner and intermediate fittings for series 1 freight containers (Reference 67).

For manual twistlocks, it is proposed that the unified direction of handling will be clockwise when viewed from above, ie lefthand locking

- checks to ensure that the spring holding the twistlock in the closed position is in a resilient condition. If a spring loses its resiliency, the cone(s) will not be held in position in a positive manner. The moving and flexing of a vessel in a seaway has been found sufficient to allow twistlocks to unlock themselves if their spring action is failing or has failed



Figure 41.10: Uniform twistlocks.

- check to ensure there are no structural defects that would compromise the proper use of the equipment, for example:
 - twistlocks with missing handles
 - twistlocks with fractured housings
 - double cones with fractured base plates
 - seized/buckled turnbuckles, bridge fittings.



Figure 41.11: Fixed fittings.

Regular inspection of fixed fittings is also essential to establish whether progressive wear has undermined their integrity. Areas requiring particular attention include:

- Reduction in the thickness of securing points where for example a turnbuckle may have chafed
- wastage in the way of the key holes of deck foundations
- wastage and cracking of the plating to which fittings are welded
- distortion of dovetail deck foundations.

If a dovetail type fitting and its associated part are compatible and in good working order, it should only be possible to slide a dovetail type twistlock or locating cone in a horizontal direction into the deck fitting. However, if the deck fitting is damaged or its associated part is incompatible, it may be possible to lift a dovetail type twistlock or locating cone out vertically. In such an event, no vertical restraint will be provided to secure a column of containers to the deck.



Figure 41.12: Worn shoe fitting.

41.3.2 Weight Management Problems in Stacks



Courtesy of Danny Cornelissen/portpictures.nl

Figure 41.13: The stacking of containers.

The most potentially damaging stacking problem occurs when heavyweight containers are loaded into the upper tiers of container bays on deck.

The problem can occur with any container ship if the permissible stack/tier weights are ignored for a specific securing arrangement. For example, modern container ships feature deck stows comprising six or seven tiers of units, which appears to represent a huge carrying capacity. However, weight limits apply and, in the upper tiers (sixth and seventh layers), only empty containers may be carried.

The operating principle is that the weights of containers should not exceed the prescribed limits for the slots in which they are stowed. These limits should be set according to stack weight, tier position and the securing arrangement being used. In modern container handling systems, the loading model for a particular class of vessel is usually sufficiently well detailed that it prevents an operator from planning the loading of a heavy container in a light slot. In a more sophisticated approach, the loading computer will calculate, on an individual stack basis, the resultant forces acting upon the containers and the lashing system. A maximum container weight will be determined for each position and it is possible that a heavy container could be received over a unit of lesser weight, provided that securing loads are acceptable. In both examples, if the weight is excessive for the specified position, the computer program will simply reject the container.

However, the container industry covers a broad spectrum and vessels that incorporate the very latest technology run side by side with others from older generations. In all cases, it is the responsibility of the ship planning coordinator and/or the loading terminal ship planner to stow the containers into the proper and appropriate positions on the ship.

Another reason for exceeding the stack loads may be misdeclared weights by the shippers. As a consequence of continued accidents resulting from this, and pressure from the shipping industry, the IMO amended SOLAS Regulation VI/2 requiring shippers to weigh containers prior to shipping and provide verification to the carrier about the total mass of each container.

The verified gross mass of a container is the total gross mass of a packed container, which is obtained by either of the following methods:

- Weighing the container after packing and sealing it
- weighing all packages, dunnage, pallets and securing materials to be stuffed in a container and adding them to the tare mass of the container.

Upon receipt of verification of the gross mass of the container, the shipper must communicate it to the carrier (and Master) via a shipping document. It should be noted that the obligation is for the shipper to provide the verified gross mass to the carrier, shipping company and the Master. The role of the ship planner in ensuring compliance with this is crucial.

Under legislation laid down by the United States Department of Labor's Occupational Safety and Health Administration (29 CFR 1917.71 *Marine Terminals: Terminals handling intermodal container or roll-on roll-off operations*) (Reference 68), all cargo containers must be weighed before being hoisted for loading. Empty containers must be checked to ensure that they are indeed empty and marked or noted as such.



Figure 41.14: Collapsed container stacks as a result of bad stowage.

Bad stowage can occur as a result of a mistake, or it may be due to complacency. The following are the main reasons why heavy containers are sometimes placed in the wrong slots:

- **Inexperience**
An inexperienced planner faced with a problem of container distribution might simply allocate stowage on the 'best possible' basis, ignoring good stowage principles and the vessel's stowage and securing criteria.
- **insufficient knowledge**
A planner who lacks specific knowledge of the tier limits for a particular vessel, or class of vessel, will not know whether a particular plan he has composed meets the criteria of the vessel's lashing system. Lack of coordination between the planners and the lashing teams may not take into account the added complications resulting from the need for sufficient strength of lashing for heavy stows.
- **late arrivals**
Errors often occur when containers are received late for shipment. The vessel may be part loaded and stevedores may have abandoned a scheduled loading plan in place of a hybrid because cargo was not available when the vessel arrived. When containers arrive late, it may be the case that only relatively high positions remain available.
- **third party stowage.**
In almost all cases, loading, stowage and securing of containers is carried out by third party stevedores with the ship's officers and crew only able to monitor their work. The quick operation of modern container gantries and the large number of containers being loaded/discharged in a short period of time mean that the ship's crew is physically unable to pay the

same attention as they would otherwise on a smaller container with slower cargo operations. This situation has been historically complicated by lack of proper access to the top of container stacks to place, for example, the stacking cones or to properly lock the twistlocks. While some of these functions remain restricted due to the quick turnaround of container ships combined with the large volume of cargo being loaded, some of the issues can be overcome by the crew's due diligence.

MSC.1/Circ.1353, published in December 2014, requires that a cargo safe access plan (CSAP) is supplied within the cargo securing manual to ensure that persons engaged in securing and stowage of containers are provided with safe access during their work. This plan details guidance for hand rails, platforms, walkways, ladders, storage facilities, fittings for specialised containers such as reefer plugs, first aid locations and any other information that may be relevant to provision of safe access.

Addressing the issue on board ship

Ships' staff should not allow loading operations to commence until they have received a copy of the proposed stowage plan. A relatively quick inspection should show whether heavy containers have been planned over light ones and whether the stack and tier weights are within the permissible limits.

Vigilance is the key and ships' staff should be aware that mistakes are often accompanied by departures from the plan. Duty officers must not hesitate to report to the chief officer on any occasion when stevedores advise there is a change to the original plan and the chief officer should look carefully at what is proposed.

Ships' staff should always check the pre-loading plan for heavy container stacks. These should be identified and, if possible, the container numbers in these stacks checked during loading. If a different container appears in the upper tier, it may be a heavy unit stowed by mistake and of sufficient weight to overload the stack and the lashing system.

Problems that may be created by incorrect stowage of this type include:

- The need for restowage of containers (and resulting delays and costs) if an overweight condition is ascertained
- collapsed container stacks
- containers lost overboard (both the overweights and containers that were not overweight)
- cargo liability claims
- chassis damage

- damage to the vessel
- stability and stress risks for the vessel
- risk of personal injury or death to seafarers and shoreside workers
- last minute shut-outs of confirmed, booked and available loads when the actual weight on board exceeds what is declared and the total cargo weight exceeds the vessel limit or port draught limit.

Container ship operators must instruct terminals to check weight against stowage slot before allowing a unit to be shipped late in a position other than that originally planned. In most cases, the plan will be sufficiently flexible to accommodate late loading, but in some instances it will not. Potential problems must be identified, and remedied, before sailing.

The most common method by which a stowage error of this type is discovered is when the chief officer updates his loading plan using the final plan, normally provided electronically. The update should tell him whether there are any changes from the pre-load plan. In more extreme cases, the discovery is made when the vessel encounters moderate weather and starts to roll and pitch. The safety margins in lashing systems are very small and an excessively heavy stack will soon begin to challenge the integrity of the securing arrangements. Container structures will be overloaded, causing fittings to fail and movement to occur.

On a modern vessel, the breakdown of the stowage usually commences in lower tiers, possibly at second tier level, where racking loads may cause failure of the door end structure. Alternatively, the compressive forces may cause buckling of a post. There may be excessive pull-out loads on twistlocks or base locks.

Once fittings have begun to fail, movement of the stack occurs and load is transferred to adjacent stacked containers and, in most cases, an entire bay of containers is at risk. Outcomes where heavy containers have been loaded in high positions have involved:

- The loss overboard and subsequent compulsory recovery of dangerous chemicals in 200 m water depths
- the capsizing of ships alongside a berth
- the collapse of stacks and spillage of hazardous chemicals on deck.

Case studies

The loading of a container ship is a complex process. Weight must be evenly distributed at the same time as ensuring that hazardous cargoes are positioned appropriately and away from other cargoes with which they might react. There have been several instances where ships have capsized or heeled to severe angles during loading or unloading.

'Deneb'

In June 2011, the container ship *'Deneb'* capsized at the Port of Algeciras during loading operations. There had been modifications to the stowage plan during loading because of safety concerns and, during the first part of loading, a heel of 10° was seen. As the final containers were being loaded, the ship listed to approximately 45°, resulting in the ship lying on the pier. Further listing was in progress when tugs managed to push the ship further onto the pier to avoid a total capsizing. It is believed that this accident was due to the weights of containers being incorrectly declared.

'Repubblica di Genova'

In March 2007, the *'Repubblica di Genova'* capsized as it was being loaded, while in berth at Antwerp. This ship was a RoRo vessel but was carrying a number of containers on deck. The cause was never determined, but a number of reports suggested that some of the containers on deck were heavier than had been declared and caused the ship to list to one side, eventually capsizing. The ship was partially under water for six months before salvage could be completed, at which point the ship underwent a total renovation and then returned to service.

41.3.3 Mixed Unit Sizes

Another cause of stack failure is where two 20 ft units are stowed on the weather deck in what would otherwise be a 40 ft unit position, making it very difficult, and sometimes impossible, to apply wires, chains or lashing bars to the adjacent end-butting corners. Their absence is not compensated for by using double or four-way inter-layer stackers (spades) or longitudinally positioned screw-bridge fittings, tie-wires or the like (see Figure 41.15).

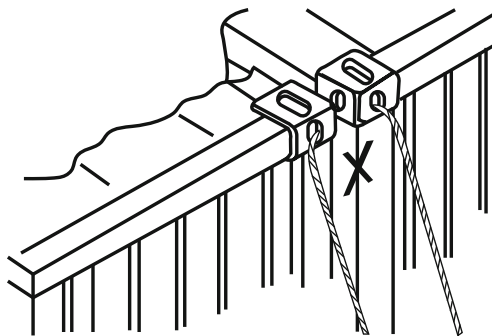

Figure 41.15: Adjacent corner castings should never be loop-lashed.

The container stack as a whole, and particularly units in the base tier, will be subject to excessive racking stresses should the ship start rolling in heavy seas or pronounced swell conditions. Some compensation can be applied by the use of anti-rack bands (two tensioned metal straps fitted diagonally across the

corners of the 'free' ends of the base tier containers) but they suffer from the same inability to secure the 'butting' ends. Sometimes, anti-rack spacers are used (see Figure 41.16), but a full lashing system is preferred.



Figure 41.16: Anti-rack spacer.

41.4 Lashings



Courtesy of Danny Cornelissen/portpictures.nl

Figure 41.17: The safe lashing of containers.

In the early years of containerisation, existing general cargo vessels were converted by the removal of tween decks and the addition of cell guides into the cargo holds. On deck, the hatch covers were strengthened and fittings added

for lashings. However, the containers on deck were seldom stowed above one high and so were secured to the vessel by 'traditional' cargo ship methods.

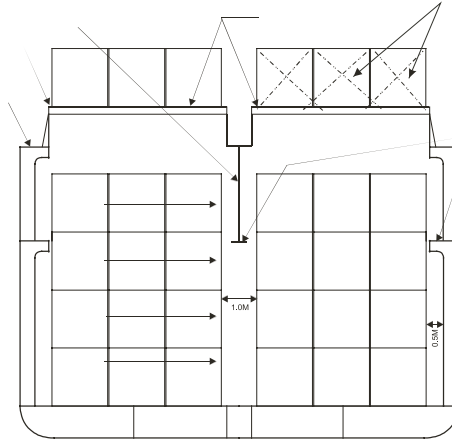

Figure 41.18: Typical midship section of an early vessel conversion.

The first generation of purpose-built container vessels had holds and hatch covers that were as wide as possible, and container posts were fitted on deck to facilitate loading of deck-stowed containers out to the ship's side (see Figure 41.19).

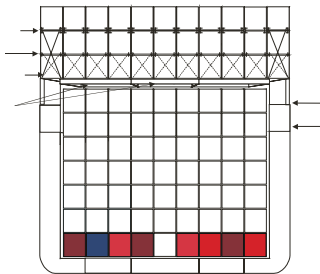

Figure 41.19: Typical midship section of an early generation cellular container vessel.



Courtesy of Danny Cornelissen/
portpictures.nl

Figure 41.20: 1990s 4,500 TEU cellular container ship.

For this generation of vessel, two systems of securing the cargo were common. One relied on the use of twistlocks in conjunction with lashing bars or chains and the other on the use of stacking cones and bridge pieces in conjunction with lashing bars or chains. Gradually, due to the increased utilisation of differing height containers, the second method became redundant and it became common practice to use twistlocks throughout the stow. This usually allowed containers to be stacked three high and, in some cases, four high if the fourth tier was light in weight or empty.

For first generation vessels, computer technology was not available on board to speedily calculate dynamic loads acting on container lashings and frames. The shipboard computer was only used to calculate stresses and stability for the ship itself. Therefore, shipboard staff would ensure the vessel was lashed according to a lashing plan taken from the lashing equipment manufacturer's manual, which tended to assume an ideal stow with respect to the distribution of weight in each stack.

With further development in the industry, the size of container ships continued to grow, with 9-high stowage in holds and 4-high stowage on deck becoming commonplace, and the industry began to realise that standards in lashing were required. Ships were at this stage still supplied with loading computers to calculate the ship's stability, shear forces, bending and, occasionally, torsion moments. Very few had the capability to calculate dynamic loads on container frames and lashing systems caused by ship motions and wind forces, so the lashings were still applied throughout the stow in accordance with the manufacturer's manual.

Following incidents such as the loss of the MOL '*Comfort*', the question has been asked whether the sheer size of these ships constitutes a risk. If a fire broke out on one of these ships, potentially millions of pounds worth of cargo is at risk and there is a relatively small number of crew available to try to get any such situation under control.

While the economies of scale demand larger container ships, the lashing systems in use on all types of container vessels are very similar and based on the twistlock and lashing bar/turnbuckle system. Large hatch openings mean that containers are partly resting on hatch covers and partly on stanchions located adjacent to the hatchway, but unequal deformities in the hull structure may lead to misalignment of container seating points. Even though the Classification Society rules provide for certain allowance in any such misalignments, the extent of these will vary between ships and, in some cases, on the same ship between various stowage locations. This will have an impact on the stresses placed on lashings and, therefore, the resulting outcomes with respect to their ability to hold a container in position.

On post-Panamax vessels, where among other features the vessel's large beam results in an unavoidable, relatively large GM (metacentric height), the practice is for the vessel to be fitted with a lashing bridge, which is a substantial steel structure running athwartships between each 40 ft container bay. This allows the second and third tiers of containers to be secured to the bridge using lashing rods and turnbuckles, while the whole stow is secured throughout with twistlocks (see Figure 41.25). The lashing bridge allows the anchoring points for each stack to be moved higher up the stack, which allows the lashings to be more effective in reducing the tipping moments acting on a stack when a vessel is rolling heavily. However, the practice of fitting the bridges between 40 ft bays means that the 20 ft containers can only take advantage of the lashing bridges at one end. So, in effect, the 20 ft stacks have to revert to the limits of a conventional lashing system. This is because the practice of estimating the

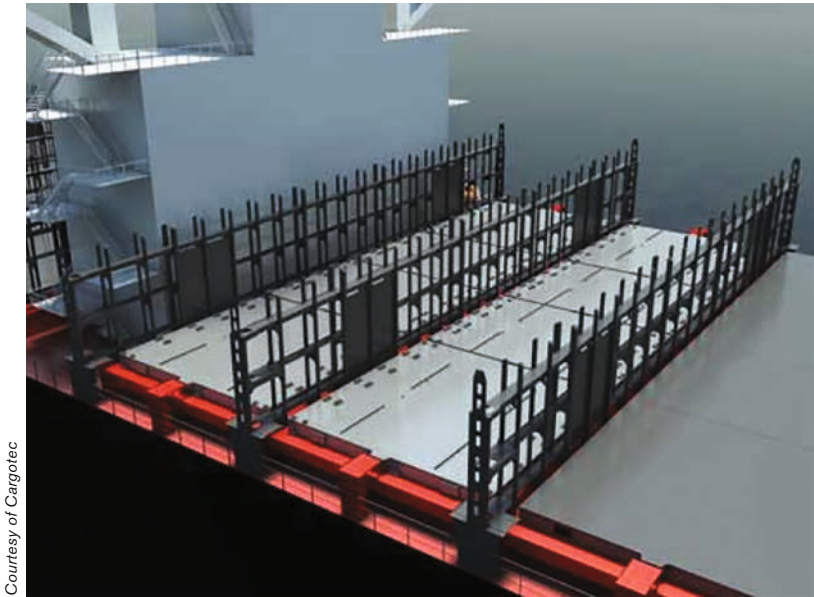

Figure 41.21: Lashing bridges.

forces acting on a stack divides the container weight equally between each end of the container. Therefore, the weight in each 20 ft container is limited by the capacity of the lashing system at the container end, which does not have the advantage of being secured by a lashing bridge.

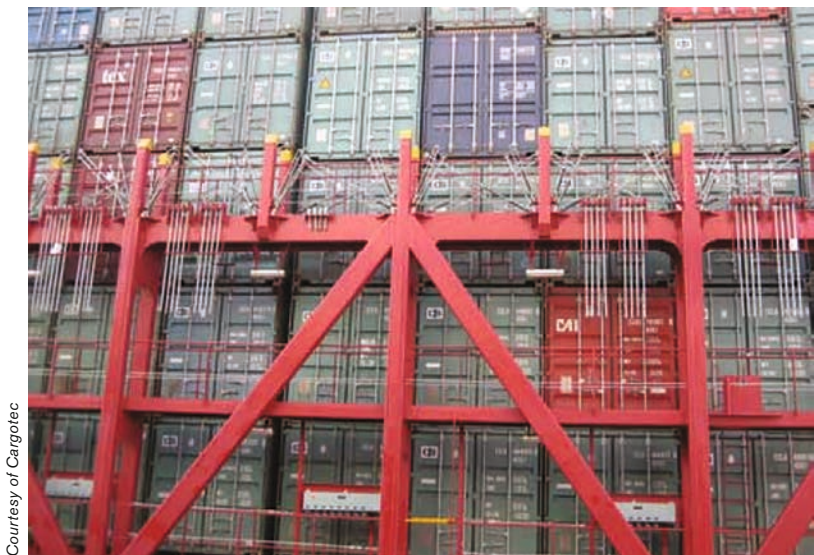

Figure 41.22: Top lashing bridge system for up to 9-high containers.

On smaller vessels, the whole stow is also secured throughout with twistlocks, and the lowest three tiers are secured to the hatch cover or support post using the lashing bar/turnbuckle combination (see Figure 41.27).

Modern vessels may have up to 9-high stowage on deck, and the use of onboard computers to check the dynamics of the stow in all weather conditions is vitally important for the safe carriage of the cargo. Development of ultra-large container ships (ULCS) has required ultra-secure lashing systems. The safety of containers on board not only depends on the speed at which modern container ships operate but also their direction of movement in relation to the height and direction of waves to control the ship's rolling and pitching motion, and so stresses on the container lashings. This type of development, combined with modification of lashing equipment such as lift-away hatch covers, fully automatic twistlocks (FATs) and the use of modern computerised systems to check loads on lashing points and equipment combined with full assessment of ship stability, can provide a complete solution.

'Napoli' case study

In January 2006, the 276 m, 4,734 TEU container ship MSC *'Napoli'* was deliberately beached in the English Channel during a strong storm after parts of the ship became flooded. It was discovered that the hull had suffered severe fractures, although the vessel remained in one piece.

The investigation determined that the hull fractures occurred because the vessel had insufficient buckling strength. Whipping and hogging in the high waves caused heavier than usual loads.

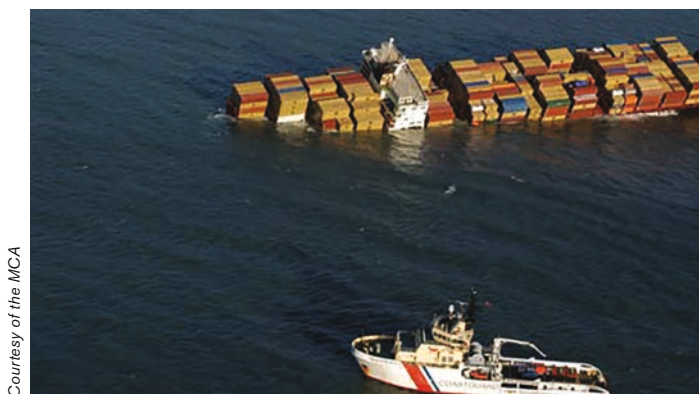

Courtesy of the MCA

Figure 41.23: MSC *'Napoli'*.

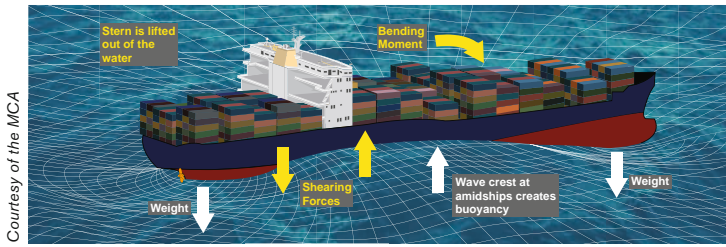

Figure 41.24: MSC 'Napoli' – simulation of forces leading to hull fracture.

The use of a computer lashing program, together with the IMO requirement for every vessel to carry on board an approved cargo securing manual, should theoretically mean a reduction in collapsed stows and losses overboard, provided the operators maintain the lashing equipment and comply with the requirements of the manual. The vigilance of ships' staff is, therefore, vital to ensure that lashings are applied correctly.

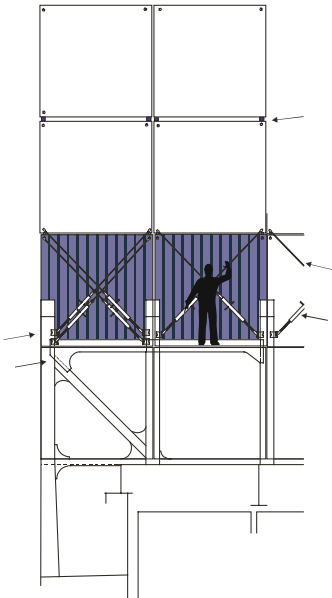

Figure 41.25: Typical post-panamax lashing bridge arrangement (shown 4 high).



Courtesy of Danny Cornelissen/portpictures.nl

Figure 41.26: Lashing a container to the lashing bridge.

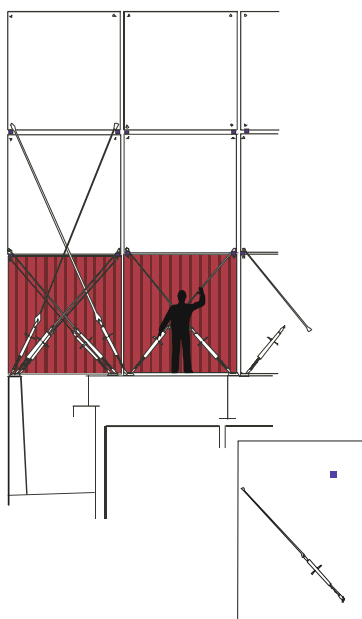

Figure 41.27: Typical container vessel's hatch cover lashing arrangement.



Figure 41.28: Tightening the turnbuckle.

41.4.1 Requirements of Lashing Systems



Figure 41.29: Typical 'on lid' loading.

The requirement to carry a cargo securing manual is specified in:

- MSC.1/Circ.1352 (and MSC.1/Circ.1352/Rev.1) – *Amendments to the Code of Safe Practice for Cargo Stowage and Securing (CSS Code)* (Reference 69) given in MSC/Circ.745(17) (Reference 70) which amends the CSS Code and provides Guidance on Providing Safe Working Conditions
- MSC.1/Circ.1353 – *Revised guidelines for the preparation of the Cargo Securing Manual*, which apply to container ships whose keels were laid on or which were at a similar stage of construction before 1st January 2015 (Reference 24).

SOLAS Chapter VI: Regulation 5, Stowage and Securing states:

“Cargo, cargo units and cargo transport units carried on or under deck shall be so loaded, stowed and secured as to prevent as far as is practicable, throughout the voyage, damage or hazard to the ship and the persons on board, and loss of cargo overboard.”

It goes on to say that:

“Freight containers shall not be loaded to more than the maximum gross weight indicated on the Safety Approval Plate under the International Convention for Safe Containers (CSC), as amended.

“All cargoes, other than solid and liquid bulk cargoes, cargo units and cargo transport units, shall be loaded, stowed and secured throughout the voyage in accordance with the Cargo Securing Manual approved by the Administration. (...) The Cargo Securing Manual shall be drawn up to a standard at least equivalent to relevant guidelines developed by the Organization.” (Reference 18)

Therefore, following MSC/Circ.745(17) (Reference 70), any Classification Society that approves a cargo securing manual will need to ensure the following:

- The guidance given in the cargo securing manual does not replace the experience in stowage and securing and the principles of good seamanship
- the information in the manual is consistent with the requirements of the vessel’s trim/stability and hull strength manual, the *International Convention on Load Lines, 1966* (Reference 25) requirements and the *International Maritime Dangerous Goods Code (IMDG Code)* (Reference 19), where applicable
- the manual specifies arrangements and cargo securing devices provided on board for the correct application to the containers, based on transverse, longitudinal and vertical forces that may arise during adverse weather and sea conditions
- such securing arrangements and devices shall be suitable and adapted to the nature of the cargo to be carried and used properly with appropriate securing points or fittings

- there is a sufficient quantity of reserve cargo securing devices on board the ship
- the manual contains information on the strength and instructions for the use and maintenance of each specific type of cargo securing device
- the manual should be updated when new or alternative types of securing devices are introduced
- the manual should consist of a comprehensive and understandable plan, providing an overview of the maximum stack weights and permissible vertical distribution of weight in stacks
- the manual should present the distribution of accelerations expected at various positions on board the ship based on a range of GM values. This information should be accompanied by a worked example showing the angles of roll and GM above which the forces acting on cargo exceed permissible limits for securing devices along with examples of calculations for number and strength of securing devices to counteract the exceeded limits
- the manual should provide information on the forces induced by wind and sea on deck cargo, and on the nominal increase of forces or accelerations with an increase in GM
- the manual should contain recommendations for reducing the risk of cargo losses from deck stows, by applying restrictions to stack weights or heights where high stability cannot be avoided
- the cargo safe access plan (CSAP) should provide detailed information for the safety of persons engaged in work connected with cargo stowage and securing.

IMO/Circ.745(17) also states that the cargo securing devices should be maintained in a satisfactory condition and that items worn or damaged to such an extent that their quality is impaired should be replaced. It is commonly accepted that obligatory survey of portable fittings is not generally pursued by the Classification Society, and so inspection and replacement should be the responsibility of the operators/Masters. Any inspections, maintenance, repair or rejection of cargo securing devices should be recorded and kept with the cargo securing manual. When replacement securing devices are placed on board, they should be provided with appropriate certification.

Portable fittings should be certified by some form of type-approval system, usually coming from the manufacturer (when approved), a Classification Society or other accepted testing body.

Ship managers may request a Classification Society to approve their particular lashing system and the lashing program software, in addition to the requirement of approving the cargo securing manual. However, until the cargo securing manual and the computer lashing program are produced and approved

together, in the same way as the ship stability loading computer and stability/loading manual are already used, there is bound to be confusion with respect to the safe capabilities of the on-deck container lashing system for each ship.

One note of caution: different Classification Societies have set their own standards for the minimum SWLs of lashing gear and maximum allowable forces acting on a container and the roll angle that any calculations should include.

Types of lashing failure

In general terms, whenever a vessel is working in a seaway, it will incur three main movements, described as rolling, pitching and heaving. These give rise to accelerations, and therefore forces, that act on the container frames and lashing system in use. Figure 41.30 illustrates the ship motions experienced by a container stack.

Of the forces acting on an individual container and its lashings as a result of these movements, the separation force is the tipping force that acts to pull out or separate the corner fittings or twistlocks. When the vessel is rolling heavily, if the separation force is excessive, it may pull the twistlocks out of the corner castings of the container, break the twistlocks at their weakest point or separate the corner castings from the main body of the container.

When the vessel is rolling heavily, and containers stowed on higher tiers are heavy, a racking force will be produced in the frame of the lowest containers. The larger the roll of the vessel, the larger the racking force will be.

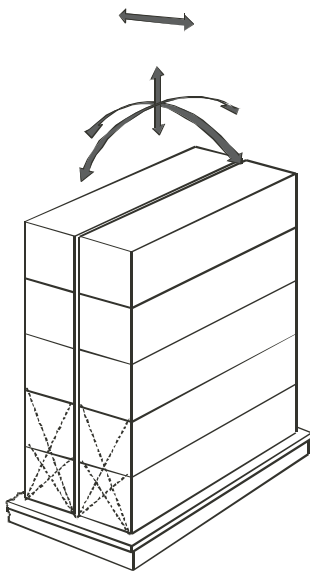

Figure 41.30: The accelerations acting on a container in a seaway.

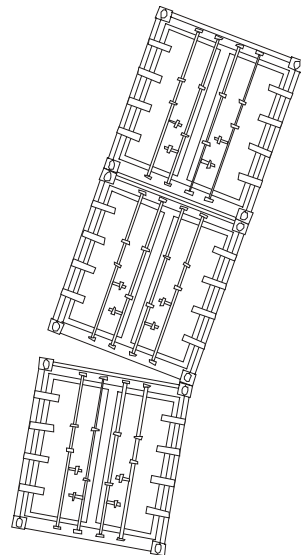

Figure 41.31: Excessive tipping moment or separation force on corner fittings.

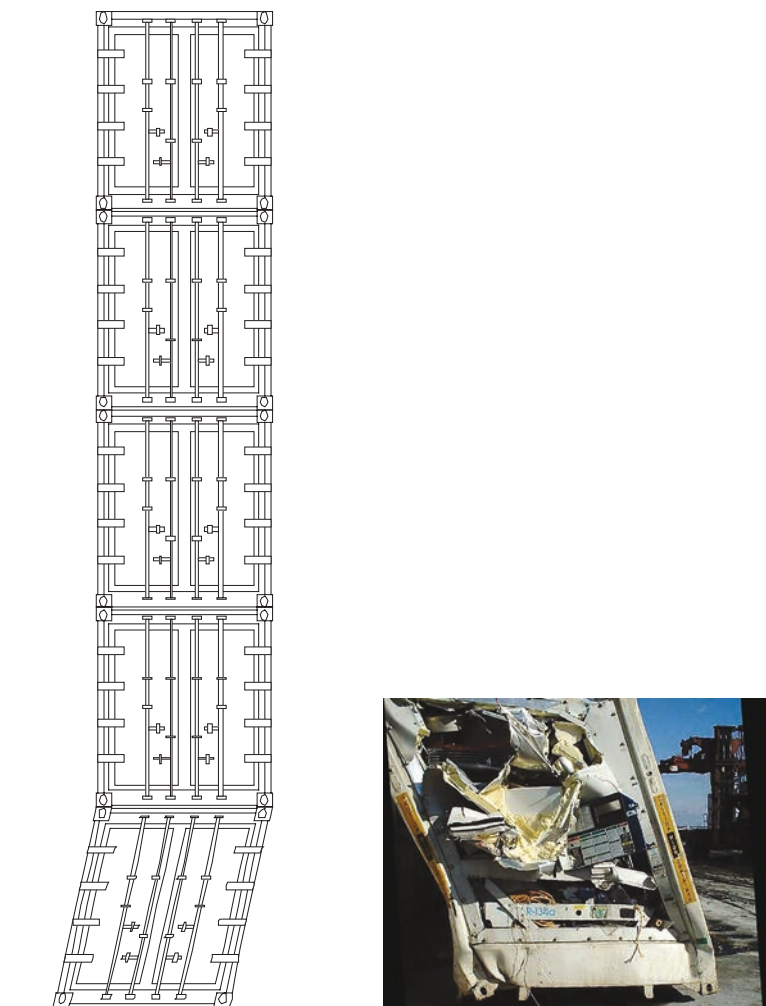

Figure 41.32: Excessive racking force on a container.

A large GM, particularly when coupled with a short roll period, increases the dynamic loadings caused by rolling, and all of the loads previously mentioned will increase the compression and tension forces acting at the corner posts of the containers and at the twistlocks between them. If excessive, they may result in structural failure of one or more of the corner posts (see Figure 41.33).

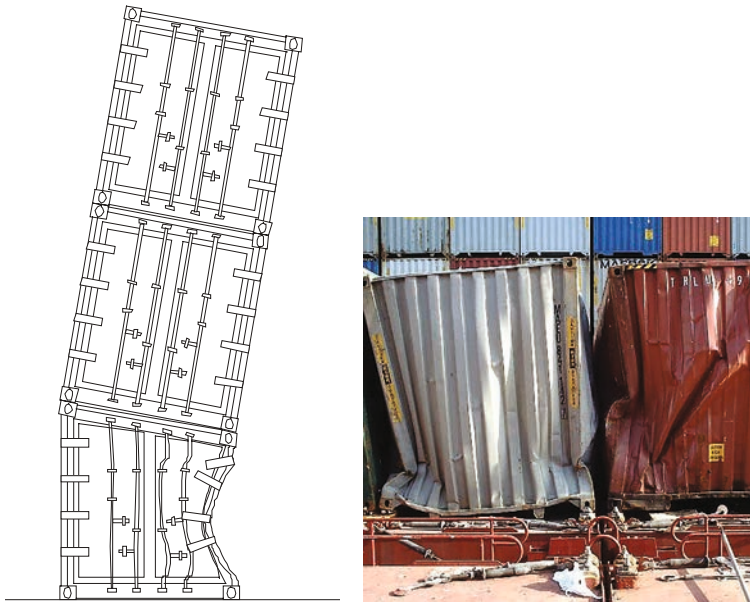

Figure 41.33: Excessive compression force on container corner post, leading to failure of the post.

Application of computer software

Analysis of incidents involving loss of containers overboard, despite correct stowage and securing, revealed that there was much ignorance concerning the combined static and dynamic loads that were present in adverse weather. In such cases, the bad weather caused severe ship motions, in particular a rolling motion. Of all the ship's motions, rolling is the most likely cause of overloading of the container frames and lashings.

It is interesting to note that the same difficulties with proper container securing and load distribution were being experienced in the mid 1980s. The solutions, in principle, are still similar but are exacerbated due to the larger size of container ships with higher stacks and increased loadings on lashings and securing points. Even though a number of computer programs are available to calculate the vessel's stability and the forces experienced within a container stack, human error continues to play some part in their effective usage. Vessel planners need to be provided with two vital pieces of information, ie the discharge port and the weight of the container. Any inaccuracies in this information will result in erroneous output, leading to the same old problems.

The situation is complicated when the chief officer, on behalf of the Master, continues to hold the responsibility for correct stowage and carriage of cargo but may not have enough time to study the information supplied by the planner to question any inaccuracies.

To aggravate the situation further, many ports supply the chief officer with an electronic bay-plan file of the pre-load plan, which should include all the relevant container data. Again, the onus is on the chief officer to check that the correct information about the container height and weight has been entered, as this affects the vessel's stability and any calculation of the forces experienced within the stack.

The benefits of using a program include assistance in achieving safer carriage of deck-stowed containers, saving on lashing requirements in terms of employment of lashing gangs, and the possibility of loading more cargo (depending on the voyage). Lashing equipment must be in good condition and certified as suitable because the calculations assume that all containers and lashing materials are in good condition and that all lashings are correctly applied, with equal tension on lashing bars, etc. These programs also calculate a theoretical angle of roll that a ship should not exceed.

Forces within a stack are affected by all ship motions, but the angle of roll is normally the most critical. Classification Society regulations assume values, which are generally the default values in loading programs. The natural period of roll can be determined using the rule of thumb formula:

$$\text{Period } (T_R) = \frac{0.7 \text{ Beam}}{\sqrt{GM}}$$

A detailed breakdown of the forces in each stack will be provided by loading programs, which include:

Racking force

This is the transverse force that tends to distort the container ends, primarily due to a rolling action. It should not exceed a maximum allowable force (MAF) of 15 t. If a lashing is applied, the force varies between the forward and aft ends of the container because of the different stiffness of the door and closed ends.

Corner shear

This is closely related to racking force, but is the force that tends to shear off the twistlocks. It should not exceed an SWL of 15 t for a standard twistlock.

Compressive force

This is the force acting on the container corner posts and fittings, which results from tilting of the stack and the vertical acceleration. It should not exceed 45 t

for a standard 20 ft container corner post or 67.5 t for a 40 ft container corner post. Larger compression forces are allowed for corner castings at the base of a stack (83.8 t).

Separation force

This is the tipping force that is acting to pull out or separate the corner fittings. It should not exceed 15 t for the top fitting and 20 t for the bottom. This force does not refer to the tensile loadings on the twistlocks.

Lashing tension

This is the tension in the applied lashings. Lashing rods should only ever be applied hand tight, not overtightened with large spanners, as this induces unnecessary tension in the lashing rod, reducing the angle of roll at which the SWL would be exceeded. The Germanischer Lloyd (GL) limit for lashing rods is 23 t SWL; turnbuckles are rated at 18 t.

If a container or item of lashing equipment exceeds its SWL/maximum allowable force, this does not automatically mean that the item will fail. SWLs are mostly set at 50% of the breaking load. The use of an SWL is to give a safety margin, allowing for occasional overstressing. A container that has been highlighted as having exceeded the Class limits will not automatically be lost if the vessel rolls to 24.9°. However, while many container stacks remain on board after having suffered greater loadings than some of those lost, calculations cannot allow for the domino effect of an inboard stack collapsing, falling against its neighbour and inducing far greater forces upon it, which in turn causes collapse.

Correct application of lashing equipment is also important and one example of incorrect application of semi-automatic base twistlocks occurs when there is an element of fore and aft movement of the container immediately prior to landing it on board so the base locks tend to be placed in the deck fitting rather than the base of the container prior to loading.

Any fore and aft movement of the container as it is aligned over the base lock risks the actuating wire being caught under the container, rendering the twistlock inoperable unless the container is lifted and landed correctly. This highlights the necessity of continual vigilance by the ship's staff during the loading process.



Figure 41.34: Twistlock failure.



Figure 41.35: Unlocked twistlock.

41.5 Containers in the Holds of Conventional Ships and Bulk Carriers

The ongoing problem of collapse of unsecured container stacks in non-purpose-built holds provides ample evidence that such stacks will not stay in place on the basis of their total weight alone.

Firm securing of the stacks to the ship's structure as a block is essential. If slackness develops during adverse weather conditions, the containers will chafe and rack, leading to overall distortion and possible collapse, particularly if heavy units have been placed in upper tiers.

ISO containers are designed to be carried by stacking them one above the other in slots or cells below deck and on the weather decks in purpose-built ships, or ships converted for such carriage. The design of bulk carriers appears to provide large, unobstructed spaces for the safe stowage of containers. They are, however, prone to severe stresses arising in a heavy seaway and containers carried in block stowages below decks can create problems if adequate securing measures are not adopted. It is not infrequent that an entire stow of containers collapses, with serious damage to the boxes and to the cargo within them.

Generally, the cargo compartments of bulk carriers are not of the right dimensions to enable the container stow to be a perfect fit. In vessels fitted with sloping hopper side tanks, for example, there will be a large area of unusable space between a block of containers and the ship's sides. Adequate measures must be adopted to ensure that the containers, as a result of rolling stresses, will not move or collapse into these spaces.

Whenever possible, the containers should be formed into one solid rigid block so that there will be no movement whatsoever. The bottom containers in the stacks should be secured to the ship's tank top plating by twistlocks

or lockable locator cones and, in addition, twistlocks or lockable inter-layer stackers should be used between each container in the stack.

Not all the containers in a block will be loaded or discharged at a single port and, as a consequence, there may be parts of a voyage when the block will be irregular rather than cuboid in shape. The stow must be fully resecured as omissions of this nature have been the prime cause of a number of casualties. In the absence of such precautionary measures, the stacking of containers two high or more will produce racking stresses, which tend to distort containers laterally.

This problem will be aggravated during heavy weather, when the weight of the containers in the upper part of the stow may cause the corner posts of the lower containers to buckle, with the inevitable result that the stow collapses. This is more likely to happen in the forward holds, where the effects of pounding are more pronounced. Ideally, all ships converting to the carriage of containers in stacks two or more high should have the securing system and the strengthening requirements for the tank tops approved by the Classification Society.

In some systems, the spaces between the containers and the sides of the holds are taken up with portable or hinged steel girder chocks that insert precisely into the corner castings of the various heights of containers. Alternatively, and in addition to the provision of any form of inter-layer stackers or twistlocks, solid bar or wire lashings may be required, tautened on turnbuckles hooked into securing points at the tank top and at higher levels adjacent to the ship's shell plating.



Chapter 42

Container Top Safety

Container top safety has been discussed in detail by various maritime organisations. The conclusions have brought about numerous changes in the applicable laws in a number of countries, most notably the USA and Japan. Both of these countries require all ships calling at their ports to comply with their legislation relating to the safety of dockworkers in the operation of loading and unloading containers. This includes the requirement that dockworkers are able to secure containers without going onto the top of containers that are stacked more than one high, whether on the quayside or on the ship. For ships to comply with the applicable law means that the equipment for fitting and securing containers on board the ship is operated from the deck, or possibly a safe walkway, level.

To ensure that containers are safely secured, automatic or semi-automatic twistlocks should be used and lashing rods need to be constructed such that they can be handled easily and safely, and secured properly without the dockworkers having to be raised above the deck, or safe walkway, level.

The top tier of a stack of containers should be secured at the top of the container and the positioning of bridge pieces normally achieves this. Dockworkers do need to be positioned on the top of containers on the top tier to fit these bridge pieces. The port or terminal normally has specialised cages fitted with fall-arrester systems to facilitate this operation.

The ILO's *Code of Practice on Safety and Health in Dock Work*, Section 16 (Reference 71) specifies the guidance for 'access to the top of a container' and requires purpose-built container ships to carry a safe means of access consisting of a stowable gantry frame fitted with suitable ladders and guarded walkways and a means of locking the gantry against movement on deck. If such a frame is not carried by the ship, a similar arrangement should be available on the dock.

MSC.1/Circ.1263 (2008) *Revised recommendations on safety of personnel during container securing operations* (Reference 72) and amendments to the *Code of Safe Practice for Cargo Stowing and Securing* (CSS Code) through MSC.1/Circ.1352 (2010) (Reference 69) further enhance the safety of workers when accessing containers. These amendments specifically require an approved cargo safe access plan (CSAP) for purpose-built container ships. However, all of these arrangements for loading and unloading ships are based on the ship being alongside a pier, quay or wharf and properly secured against unwarranted movement.

These arrangements do not mean that the ship's crew can be ignorant of these operations and the special nature of the equipment, as they will need to be able to operate these items of equipment in an emergency while the ship is at sea (SOLAS). Training in the safe operation of these pieces of equipment is an essential part of the management and running of the ship. Initial training can be carried out at shore-based facilities, provided that a sufficient mock-up of the arrangement for stacked containers on board can be arranged, but training in the ship environment is likely to be more instructive.

All training should be practised frequently, in a safe environment, and should be reviewed after each session. This is essential as the requirement for automatic and semi-automatic equipment becomes more widespread in ports and terminals throughout the world.

The ship's crew should be wary of doing any part of the job that would normally be done by dockworkers. The correct fixing and lashing of containers, irrespective of whether they are on or under deck, is a specialised job and should always be left for the specialists. Ship's personnel, who ultimately have the responsibility for the safe carriage of the cargo, should oversee the fixing and lashing on board.

Ship operators must follow the rules and regulations applicable to each port and should be aware that these are likely to vary between ports.

Any ship that does not have the particular equipment in use for a specific country's requirements should never consider trying to undertake releasing or lashing work whilst at sea, in coastal waters or manoeuvring in port limits as this would be very dangerous both for the crew and the cargo.

Despite various countries operating 'safe dockworker' principles, there should still be facilities to handle all ships that call at their ports. There should be other methods of ensuring that their dockworkers operate in a safe way, even if this means going on the tops of containers to release twistlocks (assuming that the ship does not have automatic or semi-automatic units). How they do this work is not the direct concern of the ship, as long as the ship is loaded or unloaded effectively.

Dockworkers are provided with appropriate safety equipment, such as fall-arrester harnesses and ancillary equipment, and similar safety equipment should be provided for ships' crews, even though this may only need to be used in an emergency.



Chapter 43

Container Crime

UN statistics show that an estimated 500 million containers are transported annually around the world with only about 2% inspected at various stages of the shipment, which allows an opportunity for smuggling of weapons, drugs and other contraband. To mitigate such crime, the UN Office on Drugs and Crime (UNODC) and the World Customs Organization (WCO) initiated a Container Control Programme (CCP) in 2005. This programme provides a platform for all nations involved in trade to cooperate in fighting crime related to container traffic by involving entities such as Customs, the police and port authorities. Crime prevention is managed through exchange of information, ensuring all personnel involved are trained to the same standards and follow a standardised approach.

The figures for cargo theft are estimated to be around US\$30 billion per year and are forecast to continue to increase by 8% every year. The typical locations for this type of crime are at ports, terminals or during road or rail transport. There is less of a risk while the container is on board a vessel, but vessel operators often find that they are the focal point of a claim. This is due to the fact that:

- The operator constantly accepts containers on board without actually checking the seal
- the contractual terms of the B/L provides coverage from door to door
- their assets are often more easily accessible than those of other parties.

Whatever type of container is used, its safety relies on its own security safeguards and those in place throughout its journey.

The introduction of containers was a technological advancement in the safe movement of cargo and it has had a major impact on the reduction of cargo pilferage. However, this type of transport has become a significant asset for organised crime, primarily due to the cargo involved, which offers substantial profits with minimal chance of detection.

Cargo in transit has always been the subject of crime. The distance involved in this type of movement, combined with the various handling procedures in place during the journey, presents a major obstacle to container security and it is extremely difficult to identify where a loss occurred and who carried it out. This is obviously very important when a B/L provides a door to door service.

If a container is correctly stuffed and its doors secured, there are only three ways in which unlawful entry can be gained:

- The removal of a section of the container's body
- interference with the seals on the outer container door
- interference with the container doors. The weakest links tend to be the pivot rivet connecting the door handle to the handle hub, the rivet to the swivel seal bracket and the rivets on the door hinges.

The presence of a seal on a container may provide evidence that its cargo has remained secure throughout its journey, but it is not an anti-theft device. Fortunately, there have been significant advancements in the design of seals to increase deterrence against the loss of cargo from containers while in transit.



Figure 43.1: Main photo and inset show partly removed pin on sealed door handle.

However, these improvements alone will not prevent an attack on a container because, if given the time, situation and the tools, a criminal can remove virtually any seal or section of a container's door, so the extent to which a seal offers protection is only as good as the system into which it is introduced.

For this reason, it is important that B/L issuers are satisfied that the procedures in place throughout a container's movement meet their requirements. Any discrepancies noted in the figures for container weight might be a good indication of loss of container contents, so the mandatory container weight verification requirement on shippers should be utilised. The IMO Guidelines categorically specify that the shipper named on the B/L is responsible for providing the container's verified gross mass. This requirement is likely to make stealing the entire contents of a container impossible provided the requirements are complied with diligently, particularly if the mechanism implemented requires the container to be weighed immediately prior to being loaded on the ship.

It is not only weight but also contents that need to be correctly identified to enable the crew to deal with any potentially hazardous goods in a safe manner. It has long been considered a problem in the container ship industry that shippers make false declaration of contents to avoid paying the extra charges associated with the carriage of dangerous goods.

In many instances, improved security procedures have reduced the opportunity of a loss occurring at a port or terminal, but they have not prevented the criminal from identifying a suitable cargo to steal once it has left that location.

There is, therefore, a need to constantly review procedures:

- Have you received correct documentation that verifies a container's correct weight as required by SOLAS?
- Are you satisfied that a container was correctly secured before departure from the shipper's premises?
- Are you satisfied with the haulier contracted to move a laden container on your behalf?
- Do they use sub-contractors? If so, are they suitable to undertake this work?
- Are transport instructions issued to the haulier?
- How efficient is the checking procedure of a container on its arrival at a port?
- Is there a physical check prior to a container being loaded onto a vessel? (Weakness in the system, often due to operational or financial constraints, is constantly exploited by criminals, who remove cargo prior to loading.)
- Is the seal physically checked when the container is offloaded at the destination port?
- Is the seal checked when the container leaves the port?

- Is there a procedure in place should there be an alleged irregularity on delivery? It is important whenever there is a potential loss that:
 - the seal sections are retained
 - special attention is given to the container's doors, in particular as to whether there are any different shaped rivet heads or signs of repainting.

Any irregularity should be noted, with consideration given to a surveyor's examination. It is imperative that a carrier's agent complies with the cargo release terms, which generally require presentation of the original B/L.

On occasions, agents show a lack of judgement in not complying with the release terms, but take an alternative approach without first obtaining the required authority. Such action usually relates to:

- A consignee's letter of credit
- a consignee's letter exonerating the agent from their action
- a bank guarantee confirming that sufficient funds exist in an account on a specific date
- agreement between agent and receiving party
- shipper's extended credit facility, minus the authority to release the cargo.

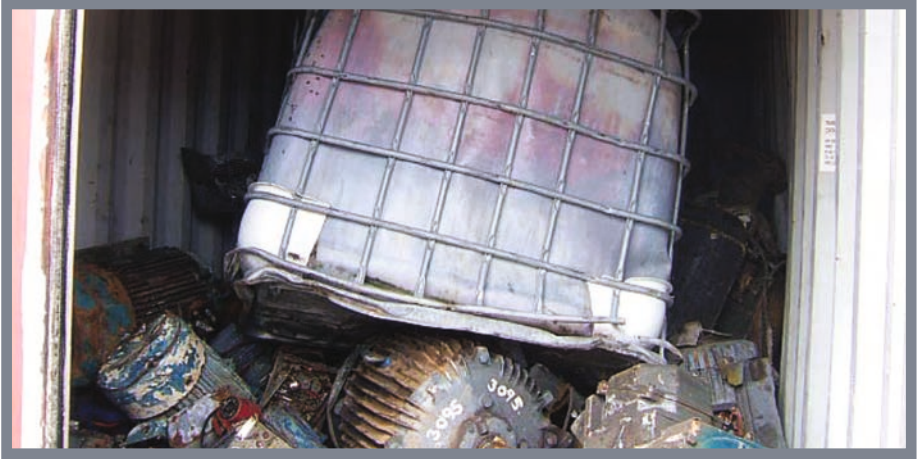

Chapter 44

Waste Shipments in Freight Containers

A container operator may face the following perils associated with the carriage of waste:

- Structural damage to the freight container due to improper stowage practices at the loadout point
- tainting of the inside of the container due to the waste having odorous properties
- imbalanced load resulting in the vehicle rolling over during road transportation
- rejection at the discharge port due to incorrect and/or incomplete documentation
- rejection at the load and/or discharge ports due to 'green waste' being contaminated and recovery unable to be undertaken in an environmentally sound manner

- risk of non-payment of storage charges at the load and/or discharge ports because the shipper/receiver fails to take timely and appropriate measures to mitigate the problems that arise following one or other of the above incidents
- the shipper/receiver abandoning their waste and the container operator being left to arrange disposal and/or return to the point of origin with the associated costs.

With the significant amount of waste now shipped in freight containers on some trades, the potential for problems can be high. For example, a vessel loading in the UK for China may have up to 65% of its containers carrying various types of recyclable waste.

A major difficulty facing a container operator is that their client, the booking party, may not be the originator of the waste. The booking party will more often than not be a consolidator or NVOCC (non-vessel operating common carrier) and will themselves be dependent upon the quality and nature of the waste being supplied to them by a third party. Therefore, while a container operator may have a good relationship with their booking party, if that party then has a new supplier, problems may be experienced. Also, problems can be masked when, say, good bales of waste are stowed in the doorway of a container concealing poor quality/contaminated bales behind.

44.1 International Waste Disposal Legislation

In the late 1980s, a tightening of environmental regulations in industrialised countries resulted in a significant increase in the cost for disposal of hazardous waste, leading to unscrupulous practices such as shipping toxic waste to developing countries.

The Basel Convention was negotiated under the authority of the United Nations Environment Programme in the late 1980s, adopted in 1989 and entered into force in 1992. The Convention was originally designed to address the uncontrolled movement and dumping of hazardous wastes, including incidents of illegal dumping in developing nations by developed world industries.

Transboundary movements of waste have increased significantly over the last decades, primarily due to the international trade for recycling purposes.

The Convention has 176 member countries (parties) and regulates transboundary movement of hazardous and other wastes by applying the 'prior informed consent' procedure (shipments made without consent are illegal). Written consent must be obtained from the States of export, import and transit. The Convention also obliges parties to ensure that hazardous and other wastes are managed and disposed of in an environmentally sound manner. Parties are expected to minimise the quantities that are moved across borders, to

treat and dispose of waste as close as possible to their place of generation and to minimise the generation of waste at source. Article 8 of the Convention requires:

“When a transboundary movement of hazardous waste, or other waste to which the consent of the States concerned has been given, subject to the provisions of the Convention, cannot be completed in accordance with the terms of the contract, the State of export shall ensure that the wastes in question are taken back into the State of export, by the exporter, if alternative arrangements cannot be made for their disposal in an environmentally sound manner.”

The Convention currently addresses 27 specific categories of waste and 18 waste streams. Annex I identifies the categories of waste to be controlled. Annex II identifies categories of waste requiring special consideration. Annex III provides a list of hazardous characteristics. Annex VIII, otherwise known as List A, identifies waste characterised as hazardous under Article 1, Paragraph 1(a) of the Convention. Annex IX, otherwise known as List B, identifies wastes not covered by Article 1, Paragraph 1(a) unless they contain Annex I material to an extent causing them to exhibit an Annex III characteristic.

Annex IX (List B) includes paper, paperboard and paper product wastes, provided they are not mixed with hazardous wastes, and covers:

- Unbleached paper or paperboard or corrugated paper or paperboard
- other paper or paperboard, made mainly of bleached chemical pulp, not coloured in the mass
- paper or paperboard made mainly of mechanical pulp (for example, newspaper, journals and similar printed matter)
- other, including but not limited to, laminated paperboard and unsorted scrap.

Annex IX (List B) also details plastic or mixed plastic materials, provided they are not mixed with other wastes and are prepared to a specification, and electrical and electronic assemblies that are metals or alloys.

44.1.1 Illegal Traffic Under the Basel Convention

Statistics compiled by the Secretariat of the Basel Convention suggest that millions of tonnes of hazardous waste are shipped internationally each year.

For the purpose of the Convention, illegal traffic is deemed to be:

- *Without notification pursuant to the provisions of the Convention to all States concerned; or*
- *Without the consent pursuant to the provisions of the Convention of a State concerned; or*
- *With consent obtained from States concerned through falsification, misrepresentation or fraud; or*

- *That [which] does not conform in a material way with the documents; or*
- *That [which] results in deliberate disposal (eg dumping) of hazardous wastes or other wastes in contravention of the Convention and of general principles of international law.*

While many countries receive hazardous waste as a welcome source of business, others receive shipments for which there is no agreement and have difficulty in dealing with it properly.

Examples of 'illegal trafficking' incidents involving shipments in freight containers include:

- 60 freight containers containing 1,600 t of waste were seized by the Dutch port authorities. The waste was declared as recovered paper, on its way to China from the UK. However, it was found to contain bales of compacted household waste, food packaging and residues, plastic bags, waste wood and textiles. The waste was first transported to Dutch ports by lorry and ferry, where the bales were then transferred into the freight containers
- 95 containers of household rubbish were seized and the exporter involved was fined US\$110,000
- a shipment of waste destined for India from the UK was declared to the customs authorities as containing paper. However, when opened by enforcement agents, it became clear, not only from the pervasive smell, that there was a mixture of wastes inside and, as well as paper, there were also plastics, wood, metals and textiles contaminated by food wastes. An attempt by the exporters to save fees payable under the correct procedure landed them with a fine of ten times as much



Figure 44.1: Compacted and tainted soft plastics.

- 89 containers were exported from England to Brazil with the cargo declared as 'plastics for recycling'. However, upon investigation, the Brazilian authorities found the containers contained plastics, tin, paper, batteries, medical packaging and soiled nappies. The Brazilian government lodged an official complaint with the Basel Secretariat, leading to one of the UK Environment Agency's largest investigations, the return of all 89 containers to England and the prosecution of three companies and five individuals.

The import of electronic waste is illegal into mainline China, but it is alleged that legislation in Hong Kong provides loopholes allowing e-waste to enter the country and make its way to scrap yards in China. The loopholes are said to include:

- No clear definition for 'reuse', 'reprocessing', 'recycling' and 'recovery operations'
- loose definition of the term 'contamination'
- not all types of electronic waste are under control and, while attention is given to old batteries and cathode ray tubes, printed circuit boards are given less attention.

Only about 50% of a computer can be recycled, comprising on average 32% ferrous metal, 23% plastic, 18% non-ferrous metal (lead, cadmium, antimony, beryllium and mercury), 15% glass and 12% electronic boards (gold, palladium, silver and platinum). The toxicity of the waste is mostly due to the lead, mercury and cadmium – the non-recyclable components of a single computer may contain almost 2 kg of lead. Much of the plastic used contains flame-retardant materials, which makes it difficult to recycle.

44.2 Area Information

44.2.1 China

Manufacturing activities in Southern China, and their increased demand for recovered scrap materials as secondary and inexpensive raw material, have resulted in a significant increase in the transboundary movement of waste for recycling purposes.

Their statistics show that between 2010 and 2014 the amount of waste imported and exported reduced from approximately 9 million tonnes to 6 million tonnes of plastics, and 1.3 million tonnes to 0.9 million tonnes of paper. However, figures from the International Solid Waste Association indicate that China's import for plastic waste increased from 5.9 million tonnes in 2006 to 8.9 million tonnes in 2012 and the figures from Trading Economics show that China's figures for import of solid waste consisting of plastics and paper reduced from US\$250 million in January 2014 to 180 million in December 2015.

However, while the figures show a decline in Chinese import of waste, the trend is likely to change as the world economy fully recovers from recession.

44.2.2 Hong Kong

Regulatory control over the import and export of waste in Hong Kong comes under the Waste Disposal Ordinance (WDO), which is enforced by the Environmental Protection Department. The WDO provides for enhanced control on movements of wastes into and out of Hong Kong through a permit system, which corresponds with the Basel Convention.

Under the WDO, any import and export of prescribed hazardous, non-recyclable and contaminated waste for whatever purpose, and import and export of other waste for a purpose other than recycling, must be authorised by the EPD (Environmental Protection Department, Hong Kong Special Administrative Region) through a permit. A person who conducts controlled waste import/export activities without a permit or disposes of any imported waste listed in the Sixth Schedule, for which an authorisation is required, commits an offence that could be subject to a fine or prison term.

With the exception of the import or export of uncontaminated waste in Annex IX, List B, of the Basel Convention for the purpose of reprocessing, recycling, recovery or reuse, all other waste import and export activities require valid permits issued by the EPD. Waste movements between Hong Kong and mainland China are subject to the same control.

'Green waste' is commonly used to describe waste that can be readily recycled and is free from contamination. For the purposes of waste import and export, waste is contaminated if it is contaminated by a substance to an extent that:

- Significantly increases the risk to human health, property or the environment associated with the waste
- prevents the reprocessing, recycling, recovery or reuse of the waste in an environmentally sound manner.

The following procedure is used to decide whether a permit is required to import/export waste into/from Hong Kong:

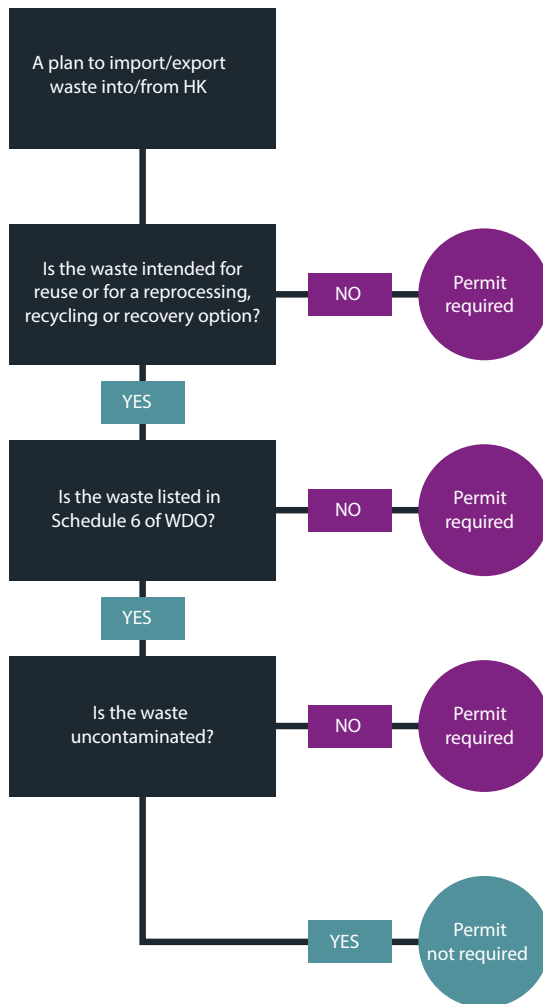

Figure 44.2: Hong Kong import/export procedures.

For green waste to be imported into mainland China, the shipments concerned may need to be inspected by designated parties at the exporting countries or other places approved by the mainland authorities. Importers, exporters, traders or any parties concerned should confirm the latest requirement prior to effecting any shipments destined for the mainland.

The Ministry of Environmental Protection of the People's Republic of China (MEP) (formerly SEPA) is the designated authority for the environmental

management of solid waste imports and is responsible for issuing two kinds of import licence:

- Import licence of the People's Republic of China (PRC) for *automatic* licensing of solid wastes that can be used as raw materials
- import licence of the People's Republic of China (PRC) for *restricted* solid wastes that can be used as raw materials.

Imports should have:

- A Waste Import Licence issued by MEP – this is obtained by recyclers and/ or utilisers of the imported waste in China prior to the waste import
- a License of Registration for Overseas Supplier Enterprise of Imported Scrap Materials issued by AOSIQ (AOSIQ Licence)
- a CCIC Pre-Shipment Certificate – Certificate for Pre-Shipment Inspection of Recycling Scraps to China (pre-shipment inspection certificate).
More information may be obtained from <http://www.ccic-europe.com> or <http://www.cciclondon.com>.

CCIC is an inspection and certification company recognised by the General Administration for Quality Supervision, Inspection and Quarantine (AOSIQ) and accredited by the China National Accreditation Service for Conformity Assessment (CNAS). A number of CCIC offices have been set up around the world in countries that export waste materials to China. Container operators who accept waste product bookings to China should request the AOSIQ licence number at the time of booking, as it confirms that the shipper is approved by the Chinese Government authorities to ship waste products to China.

The Chinese Government continues to approve overseas scrap suppliers and at the same time monitors existing suppliers for the quality of waste supplies. During their inspections, if they find any anomalies, they may simply warn the suppliers and require them to rectify any issues. However, if these issues are not rectified or in the case of serious non-conformities, their licences may be cancelled. Container operators can check the AOSIQ website (www.ccc-us.com) for a list of warned/cancelled/suspended registration numbers. Container operators should not accept bookings from shippers whose registration numbers are on this 'black list'.

It is good practice for the shipper to provide a copy of the documentation to the container operator as early as possible, but not later than the cut-off time for loading on the main line carrier. If a shipper has not submitted the export declaration, it is likely that they have not sold the cargo to a specific consignee. This increases the chances of cargo being abandoned at destination.

The list of solid wastes prohibited against import includes some 84 types, such as urban garbage, medical waste, waste organic solvent, waste clothes, waste tyres and tyre pieces, battery waste and scrap, used batteries, waste animal and plant products, waste rubber and leather, waste speciality paper, waste glass, as well as household appliances and waste electric motors including air-conditioners, televisions and computers (including their parts and accessories,

dismantled parts, broken parts and scraps unless stipulated otherwise by the state). The container operator's booking department needs to be familiar with such prohibitions.

44.2.3 EU Regulations

Commission Regulation (EC) 660/2014 amended Regulation 1013/2006 that had applied since 1²th July 2007 covering the shipment of waste (Reference 73). Commission Regulation (EC) 1379/2007 amended Annexes 1A, 1B, VII and VIII of Regulation (EC) 1013/2006 (Reference 74). Annexes III, IIIA and IIIB covered different types of non-hazardous waste, whilst annexes IV and IVA covered different types of hazardous waste. These regulations were supplemented by Regulation (EC) 1418/2007 *concerning the export for recovery of certain waste listed in Annex III or IIIA to certain countries to which the OECD (Organisation for Economic Co-operation and Development) Decision on the control of transboundary movements of waste does not apply*. Under these rules, stricter procedures must be followed (Reference 75).

Despite several EC regulations, gaps were identified in the enforcement and inspections carried out by EU member states. Regulation 660/2014 is designed to cover these gaps by strengthening Regulation 1013/2006 and providing a mechanism for planning of waste shipment inspections and to prevent illegal shipments. It also requires member states to make publicly available the outcomes of inspections and any measures taken, including penalties imposed on any parties.

It also clarified that the inspection of shipments must include verification of documents, confirmation of identity and physical checking of waste at any of the following stages of transport:

- a) *at the point of origin, carried out with the producer, holder or notifier;*
- b) *at the point of destination, including interim and non-interim recovery or disposal, carried out with the consignee or the facility;*
- c) *at the frontiers of the Union; and/or*
- d) *during the shipment within the Union.*

Under the present regulations (EC Regulation 1418/2007) (Reference 75), there are three options:

- Prohibition
- notification controls
- green list controls (lowest level of control).

Prohibition

Movements are not allowed under any circumstance, including almost all:

- Imports and exports for disposal
- exports of hazardous waste to developing countries, even if moving for recovery.

Notification controls

These apply to all allowed imports and exports of:

- Hazardous waste moving for recovery operations
- all types of waste moving for disposal
- some shipments of non-hazardous waste to non-OECD countries (includes Annex IIIB waste).

Green List controls

These controls contained in Article 18 of Regulation 1013/2006 (Reference 76) require that the exporters of waste must:

- Ensure that the Green List waste type can still be sent to that country under Green List controls
- know where the waste is going to be recovered in the destination country before shipping the waste
- ensure the waste is dealt with in an environmentally sound manner throughout its movement and recovery
- complete the Annex VII document specified in the rules with all the required information, including details of the producer or collector of the waste and the destination facility before shipping the waste (a copy of this document must be retained for 3 years)
- ensure that a copy of the above document accompanies the waste
- enter into a written contract containing specified provisions for the recovery of the waste with the person receiving the waste before the waste is shipped
- ensure that the person receiving the waste in the destination country signs the document that accompanies the waste to confirm receipt.

Waste being exported under Green List controls must be accompanied by a completed Annex VII form. The person who arranges the shipment of the waste must complete and sign this form. It is good practice for the shipper to provide a copy of this documentation to the container operator as early as possible, but not later than the cut-off time for loading on the main line carrier.

44.2.4 United States of America

The Resource Conservation and Recovery Act (RCRA) is the public law in the United States that creates the framework for the proper management of hazardous and non-hazardous solid waste.

Since the United States is not a party to the Basel Convention, it can export waste to those countries with which the US Government has negotiated a separate waste trade agreement.

44.3 Shipments of Waste at the Load Port

The first indication for a container operator that there is anything untoward with a container load of waste is when it is received by the loading terminal and the container is damaged. This is most likely to be the sidewall panels bulging outwards beyond their accepted envelope. Figure 44.3 is a series of pictures that show different problems with waste shipments.



Picture 1 shows the stow in the doorway when the container was opened. The container had been loaded with bales of waste plastics (eg bottles and packages). The bales were of rectangular shape with a long tack (right-hand bale) and a short tack (two left-hand bales).



Picture 2 shows the right-hand side bales stowed tight to the underside of the roof panel. This was because two bales had been stowed with their long tack upright. This resulted in the roof panel bowing upwards. The bales were also of non-uniform size.



Picture 3 is from an incident where the exporter had declared his shipment as being three container loads of electrical motors. However, these had been thrown into the containers with other rubbish that included plastic intermediate bulk containers (IBCs).



It is not always possible to identify the cause of damage to the structure of a container from a doorway inspection at the loading terminal. Identification of the cause may only be possible when the container is unpacked, which may take place some distance from the port.



Picture 5, shows an incident where it was found that the top right-hand bale of waste paper in the row (marked by the red arrow) was 'canted' at an angle on the horizontal plane. This resulted in pressure being applied during the course of loading to the left and right-hand sidewall panels, resulting in them bulging outwards and being permanently deformed by up to 100 mm.



Picture 6, shows another incident where the cause of damage became apparent during unloading. The bale of waste paper in the top left-hand row was not stowed with its side parallel to the fore and aft line of the container, but was 'cocked' at an angle thereby increasing its width in the stow. This bale was stowed adjacent to the maximum bowing outwards of the left-hand sidewall panel.



Poor stowage of bales within the container was not the only problem. The waste paper was contaminated with tin cans, some of which had sharp jagged edges, plastic bottles, plastic bags, pieces of wood and twigs, and a complete inflatable rubber mattress.



Waste paper contaminated with other such waste cannot be recovered in an environmentally sound manner. This type of waste should not be moved under Green List controls.

The container below was rejected by ship's staff at the time of loading because liquid was leaking out from the door seal. When inspected at the terminal's leaker bay, the front of the door sill was found to be heavily stained with a black oily substance.



When the container doors were opened, a distinct oily type odour was detected and emulsified oil was found on top of the door sill. Two solid plastic IBCs were stowed in the doorway, containing shredded plastic waste.



Behind these IBCs, shredded plastic waste had been stowed loose to approximately half the height of the container.



Other IBCs had been stowed on top of the loose shredded plastic waste. These IBCs were free to move, which would have made the container unstable during handling and transportation.

Figure 44.3: Different problems with waste shipments.

